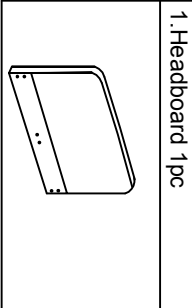
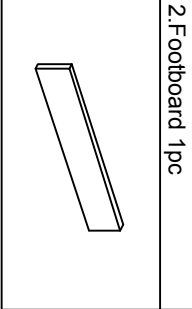
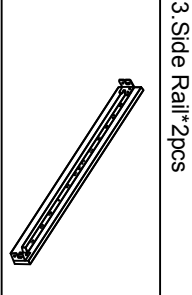
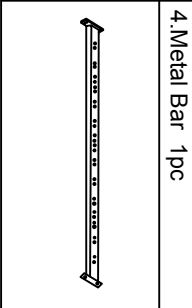
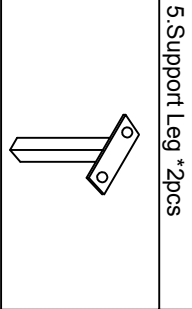
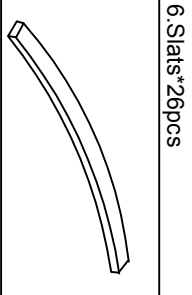
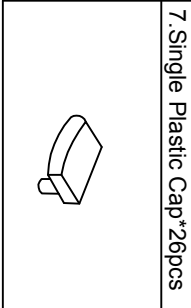
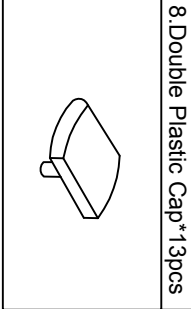
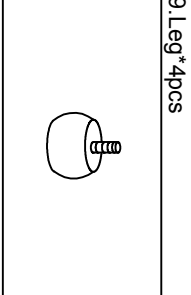
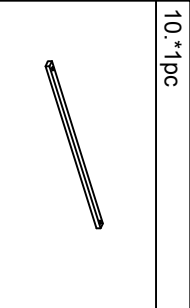
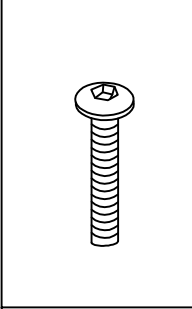
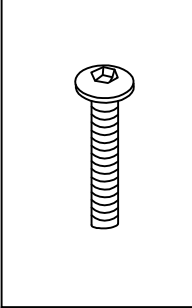
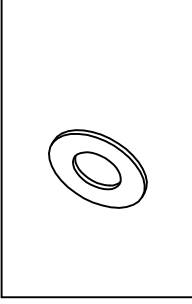
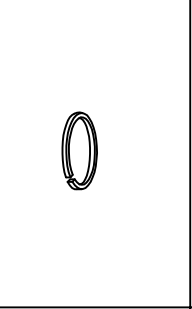
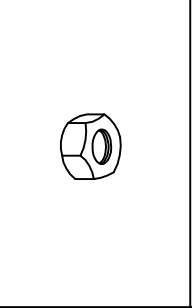
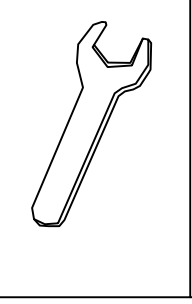
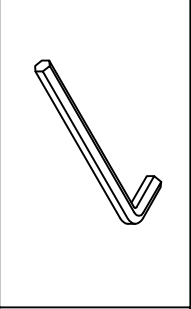

PART LIST

 1. Headboard 1pc	 2. Footboard 1pc	 3. Side Rail*2pcs
 4. Metal Bar 1pc	 5. Support Leg *2pcs	 6. Slats*26pcs
 7. Single Plastic Cap*26pcs	 8. Double Plastic Cap*13pcs	 9. Leg*4pcs
 10.*1pc		

HARDWARE LIST

 (A) Bolt M8*30mm*16pcs	 (B) Bolt M8*20mm*2pcs	 (C) Flat Washer *8pcs
 (D) Spring Washer*8pcs	 (E) Nut M8*4pcs	 (F) Spanner *1pc
 (G) Allen Key M5*1pc		

1

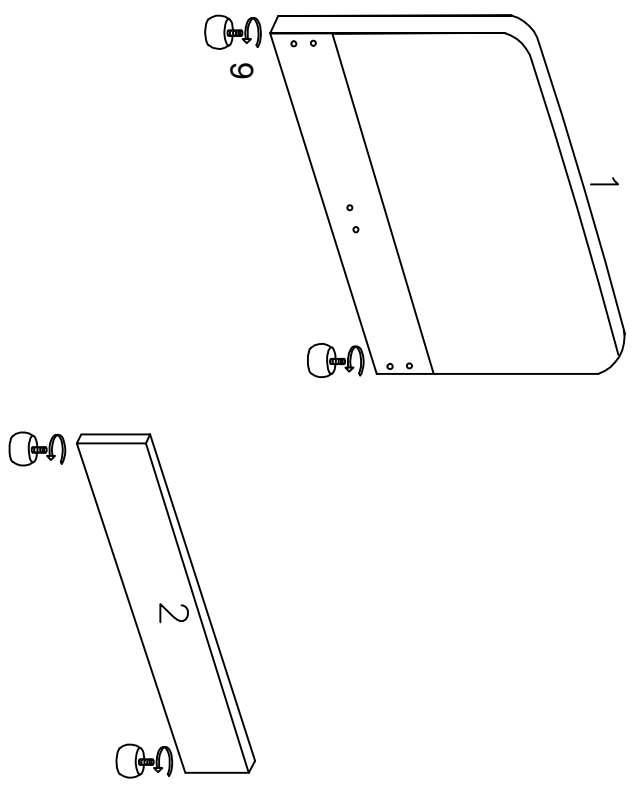

2

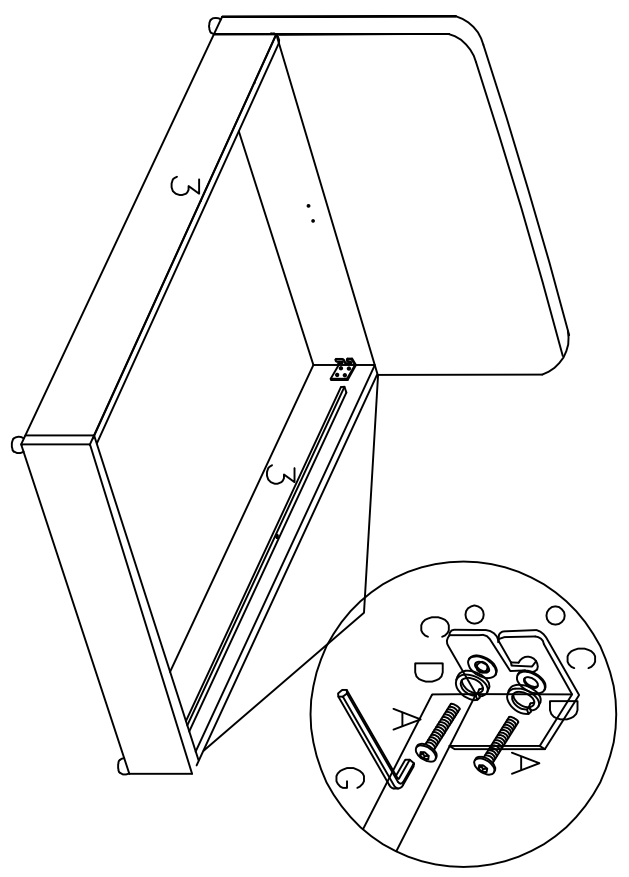

3

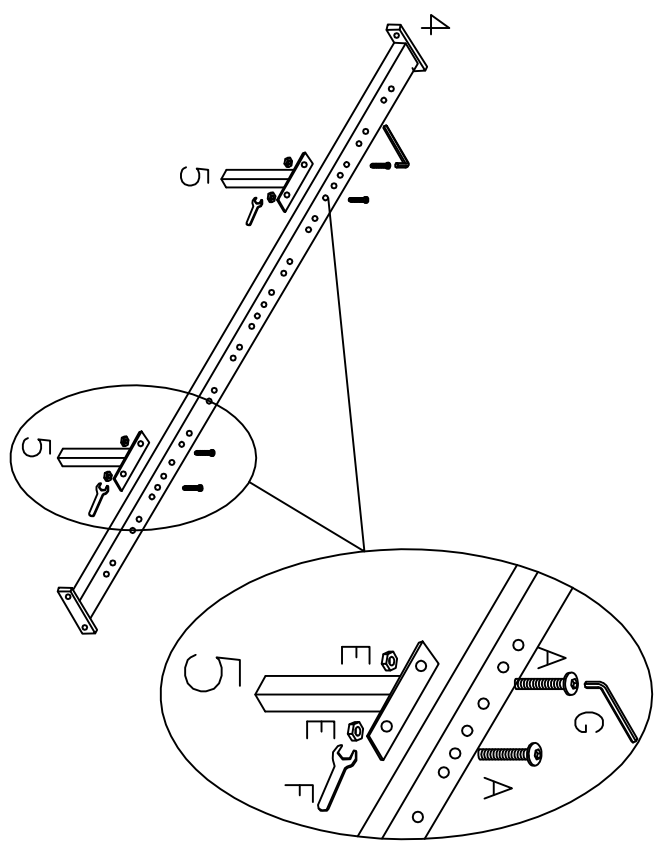

4

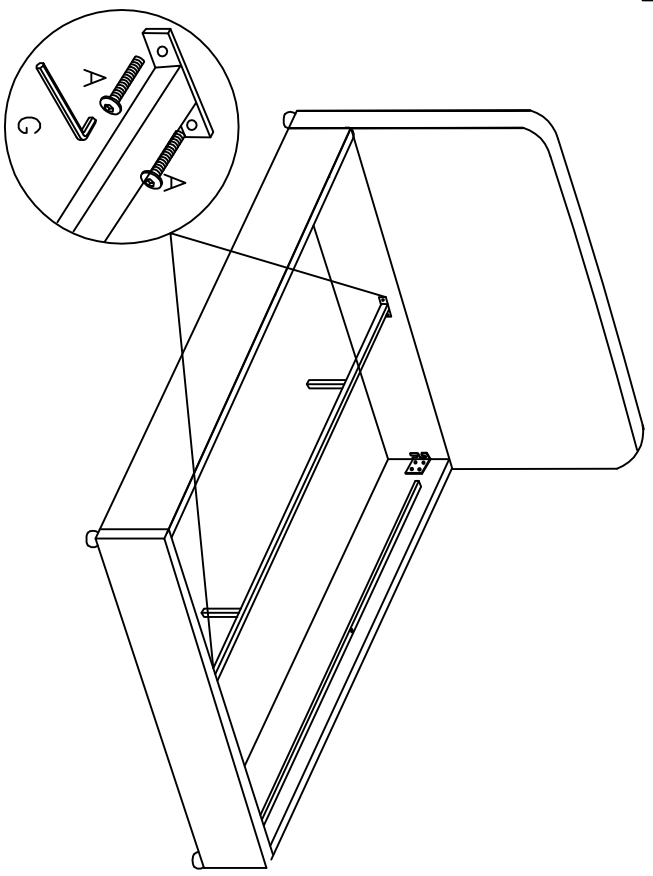

3

5

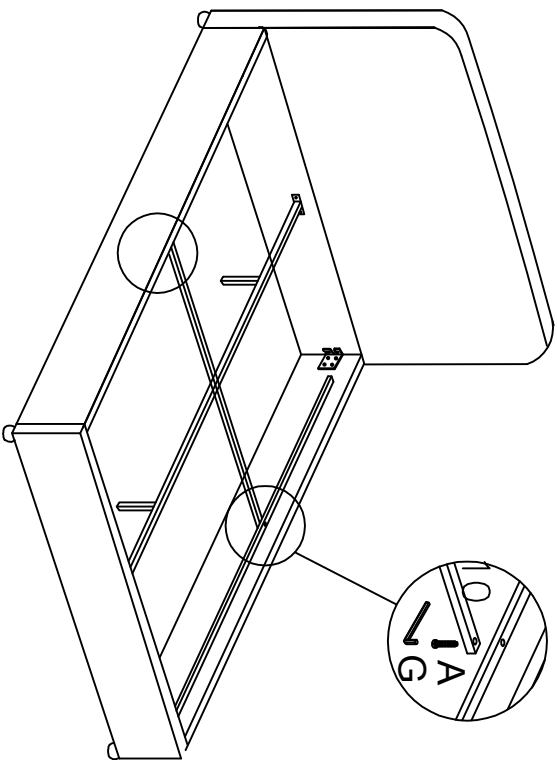

6

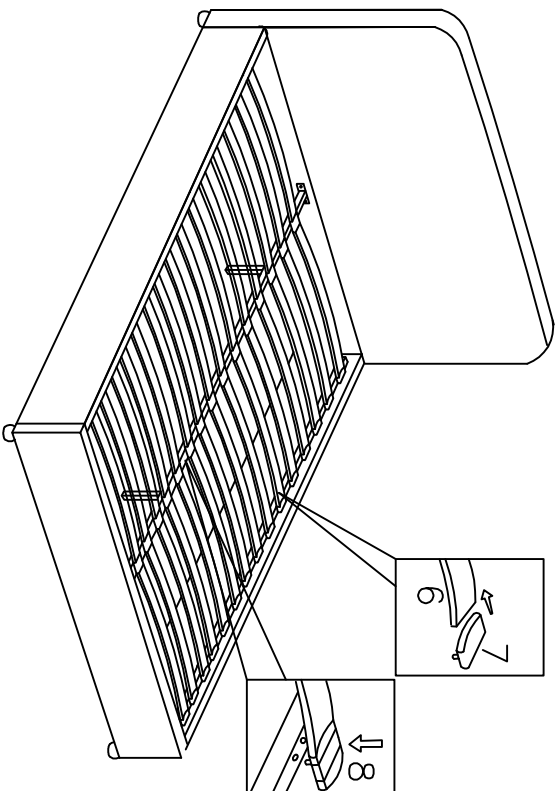

7

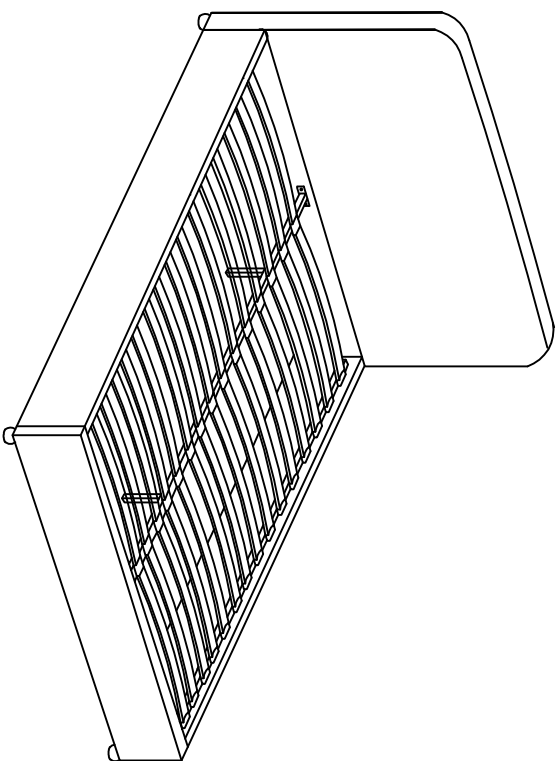

4